

Table of Contents

Introduction	2
Shelby GT500 unique features	4
Driving your Shelby GT500	8
Alternate calibration	8
Transmission operation	8
Driving through water	9
Ground clearance	9
Washing your vehicle	9
Chassis	10
Lug nut torque	11
Roadside Emergencies	15
Temporary mobility kit	15
Fuses and relays	22
Wrecker towing	24
Maintenance and Specifications	28
Engine oil	29
Air filter(s)	33
Part numbers	34
Refill capacities	35
A word about warranty coverage	40

All rights reserved. Reproduction by any means, electronic or mechanical including photocopying, recording or by any information storage and retrieval system or translation in whole or part is not permitted without written authorization from Ford Motor Company. Ford may change the contents without notice and without incurring obligation.

Copyright © 2006 Ford Motor Company

Introduction

WELCOME

Congratulations on your decision to purchase or lease the latest from Ford SVT — the Shelby GT500. If you've owned or leased an SVT product in the past, we're glad you're back. If this is your first SVT vehicle, welcome to the SVT family! We are confident that our dedication to quality, craftsmanship and customer service will ensure many miles of exhilarating, safe and comfortable driving in your new Shelby GT500.

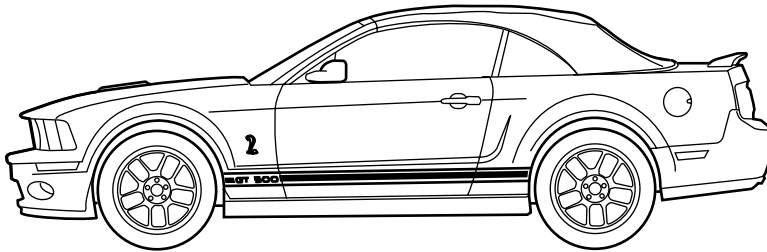

Your choice of an SVT product is an intelligent and informed one. SVT strives to build engaging vehicles that involve the driver in every aspect of the driving experience. Although performance is at the heart of every SVT vehicle, we go much further. Our goal is to deliver a comprehensive, complete vehicle, sweating the details such as the sound of the exhaust, the quality of the interior materials, and the functionality and the comfort of the seats, to ensure that the driver enjoys not only exceptional performance but an outstanding *driving environment* as well. In the Shelby GT500, that philosophy is expressed by a sophisticated powertrain, outstanding chassis dynamics and significant interior and exterior enhancements.

This supplement complements your *Mustang Owner's Guide* and provides information specific to SVT and the GT500. By referring to the pages listed in this supplement, you can identify those features, recommendations and specifications unique to your new SVT vehicle. If there are any discrepancies between this supplement and the Mustang Owner Guide, this supplement shall supersede the information found in the Mustang Owner Guide for the 2007 Shelby GT500.

Introduction

SVT HISTORY

The Ford Special Vehicle Team (SVT) was established in 1991 to “Polish the Ford Oval” by creating low-volume, factory-produced vehicles designed for those select few whose idea of driving is a high-powered, passionate experience — not just a means of getting from point A to point B.

In a move to support this spirited enthusiasm, Ford Motor Company carefully integrated the wide array of talent in the company into a small, cross-functional group of engineers, product planners and marketing people, housed together under one roof with a common mission: to create vehicles specifically designed to meet the unique needs and desires of the knowledgeable driving enthusiast.

Each of nearly 150,000 SVT vehicles produced since the 1993 model year has been designed and developed with the four SVT Hallmarks in mind: Performance, Substance, Exclusivity and Value. These hallmarks have driven the SVT Mustang Cobra and the Cobra R, the SVT F-150 Lightning, the SVT Contour, the SVT Focus, and now the Shelby GT500.

We are proud and passionate about what we do, and we’re glad you have made us your choice.

Shelby GT500 unique features

UNIQUE FEATURES

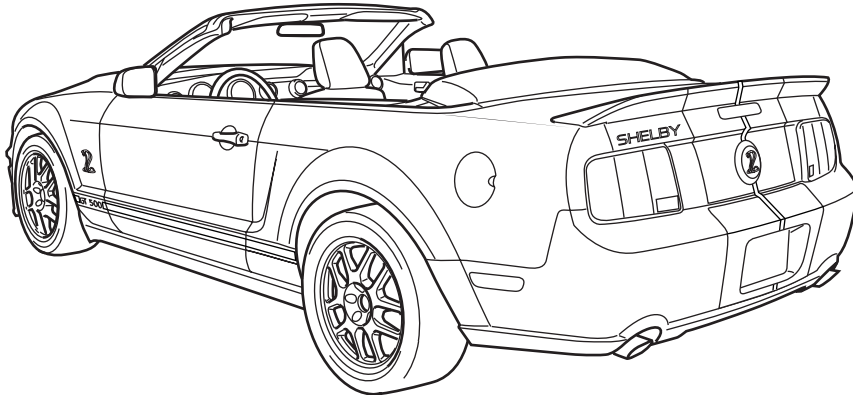

- 5.4L DOHC 32V Supercharged V-8 Engine with Intercooler — 485 Horsepower @ 6,000 rpm, 475 lb-ft torque @ 3,750 rpm
- Engine oil cooler
- TR-6060 6 speed manual transmission
- Dual Disc Cera-Metallic Clutch
- Anti-lock Brake System with Traction Control™
- High Performance Brake Pads
- Front Brakes: Brembo 14 in Vented Disc with four piston Aluminum Calipers
- Rear Brakes include unique friction material
- SVT Tuned Front and Rear Suspension
- 18 in x 9.5 in Cast Aluminum Wheels
- Front tires: P255/45R18 Goodyear Eagle F1 Supercar
- Rear tires: P285/40R18 Goodyear Eagle F1 Supercar
- Specially tuned exhaust system with X pipe

4

Shelby GT500 unique features

- Unique Front Fascia, Rear Fascia, Splitter, Fog lamps, Hood with Functional Air Extractors, Decklid spoiler
- Flat blade wiper system
- Unique cluster with boost gauge and programmable performance shift indicator
- Unique Shelby GT500 Seats
- Leather-wrapped sport steering wheel, Shift Boot and Parking Brake Handle
- I/P Appliques, door panels, and scuff plates

SHELBY GT500 INSTRUMENT CLUSTER

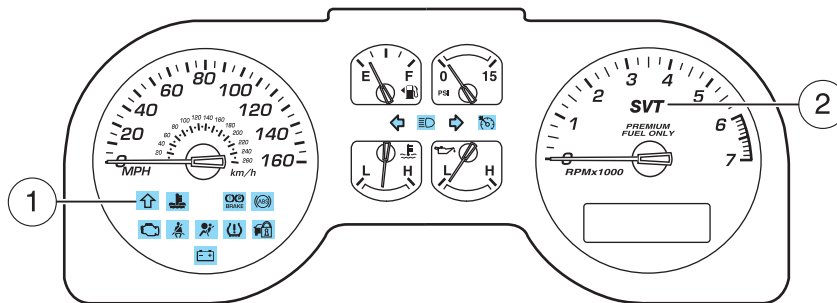

Upshift

Illuminates when it is best to shift to the next highest manual transmission gear to maximize fuel economy.

Multi Shift indicators:

1. Upshift (): Set for maximum fuel economy
2. SVT: Performance Shift Indicator (1)

Performance Shift Indicator

Your vehicle is equipped with a programmable Performance Shift Indicator. When activated, this feature provides a visual (SHIFTLAMP) and /or audible (SHIFTTONE) cue to shift to the next highest gear at an engine rpm specified by the driver.

Shelby GT500 unique features

The SHIFTLAMP feature uses the SVT logo on the tachometer to notify you when the desired shiftpoint is reached. The SVT symbol is backlit in red under normal driving conditions (SHIFTLAMP OFF). When the SHIFTLAMP is set to ON, the red back lighting is turned off and the SVT logo will turn bright orange when the desired shift point is reached.

The SHIFTTONE feature uses an audible tone to notify you when the desired shiftpoint is reached.

SHIFTLAMP and SHIFTTONE can be used separately, together, or turned off completely.

To use the Performance Shift Indicator feature, **first bring the vehicle to a complete stop** then use the Message Center controls as follows:

1. Press SETUP repeatedly until PRESS RESET TO SET SHIFTPOINT appears in the display.

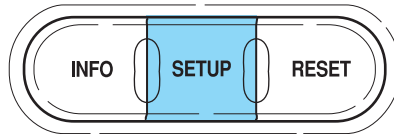

2. Press RESET to toggle between SHIFTLAMP ON/OFF. Press SETUP when finished.

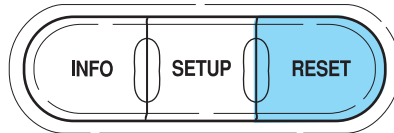

3. Press RESET to toggle between SHIFTTONE ON/OFF. Press SETUP when finished.

4. Press INFO to lower the desired SHIFTPOINT in increments of 100 rpm.

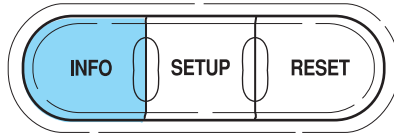

5. Press RESET to raise the desired SHIFTPOINT in increments of 100 rpm.

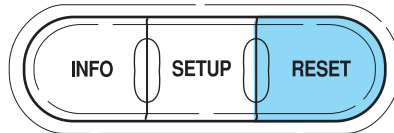

Note: The SHIFTPOINT can be adjusted from 1,500–6,000 rpm.

Shelby GT500 unique features

The Performance Shift Indicator feature functions independently of the fuel economy Upshift Indicator (⬆️). The Upshift Indicator will still illuminate when it is best to shift to the next highest gear to maximize fuel economy regardless of the Performance Shift Indicator Settings.

Message Center

The following are possible messages you may see in your Shelby GT500 Message Center:

CHECK TRACTION CONTROL™: Displayed when the Traction Control™ system is not operating properly. If this message is displayed on the message center, the Traction Control™ system will be partially operable. If this warning stays on, contact your dealer for service as soon as possible. For further information, refer to *Traction Control™* in the *Driving* chapter in your *Owner's Guide*.

TRACTION CONTROL™ ACTIVE: Displayed when the Traction Control™ system is active. For further information, refer to *Traction Control™* in the *Driving* chapter in your *Owner's Guide*.

Note: When traction control is turned off, it is possible to lose traction. If you attempt to shift with the rear wheels spinning with a loss of traction, it is possible to cause damage to the transmission. Do not attempt to shift when the rear wheels do not have traction. Damage caused by misuse of the vehicle is not covered.

ENGINE FAIL SAFE MODE: Displayed when the engine has defaulted to a 'limp-home' operation. If the warning stays on or continues to come on, contact your dealer as soon as possible.

Unique instrument cluster lighting

Your vehicle is equipped with a unique instrument cluster color display. In place of ORANGE, you can select R-W-B which will illuminate the speedometer in RED, the Fuel/Boost/Temp/Oil Pressure gauges in WHITE and the tachometer in BLUE. (Pointer colors are not adjustable).

The instrument cluster will momentarily display the R-W-B coloring when the ignition is turned to ON or START and will then return to the previously chosen color.

For instructions on how to set the instrument cluster display color or MyColor™, refer to *Message Center — Display Color* in the *Driver Controls* chapter in the *Owner's Guide*.

Driving your Shelby GT500

ALTERNATE CALIBRATION

Your 2007 Shelby GT500 Power Train Control Module (PCM) strategy contains a feature to limit supercharger boost pressure and engine speed to 4000 RPM for the first five consecutive miles of vehicle operation or 50 engine start / warm up cycles. This feature is enabled prior to shipment. If neither of these conditions have been satisfied prior to customer delivery, full power will not be available.

MANUAL 6 SPEED TRANSMISSION OPERATION

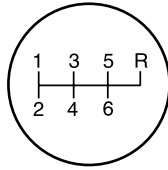

Using the clutch

The manual transmission has a starter interlock that prevents cranking the engine unless the clutch pedal is fully depressed.

To start the vehicle:

1. Make sure the parking brake is fully set.
2. Press the clutch pedal to the floor, then put the gearshift lever in the neutral position.
3. Start the engine, then press the brake pedal and release the parking brake.
4. Move the gearshift lever to 1st gear, then slowly release the clutch pedal while slowly pressing on the accelerator.

During each shift, the clutch pedal must be fully depressed to the floor. Failure to fully depress the clutch pedal to the floor may cause increased shift efforts, prematurely wear transmission components or damage the transmission. Make sure the floor mat is properly positioned so it doesn't interfere with the full extension of the clutch pedal.

Do not drive with your foot resting on the clutch pedal or use the clutch pedal to hold your vehicle at a standstill while waiting on a hill. These actions will reduce the life of the clutch.

Due to the high performance of the powertrain, a certain amount of noise from the transmission is normal. This noise will be most noticeable when the vehicle is idling in neutral with the clutch pedal out but can also occur when driving away from a stop.

Driving your Shelby GT500

Your vehicle is equipped with a twin disc cera-metallic clutch. This clutch incorporates racing technology to combine a low inertia clutch assembly with a very durable friction material with high torque capability. Depending on your driving technique, the smoothness of how the vehicle reacts to clutch engagement may be different from other vehicles you have driven. This behavior is typical of a cera-metallic clutch and is not indicative of any abnormal issues with your vehicle.

DRIVING YOUR SHELBY GT500 THROUGH WATER

The Ford Shelby GT500 has aerodynamic devices attached to the underbody designed to help control airflow for superior performance. Therefore, the driver must be especially careful to avoid driving through deep or standing water. If driving through deep or standing water is unavoidable, proceed very slowly. Never drive through water that is higher than the bottom of the wheel rims.

GROUND CLEARANCE

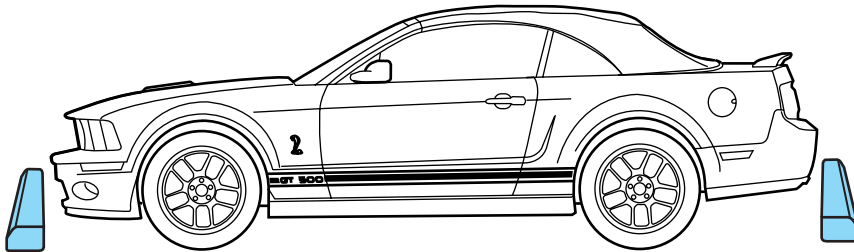

Note: Because of low vehicle ground clearance, use caution when approaching curbs/curb stops from the front and rear as vehicle damage could occur.

WASHING YOUR SHELBY GT500

Do not drive your vehicle through an automated, commercial car wash due to the vehicle's low ground clearance, tire width and track. Wash your vehicle by hand, with a commercial wand, or by using a touchless commercial wash with no mechanical tracks on the floor.

Chassis

SUSPENSION

- 8.8 in. solid rear axle with limited slip differential (3.31:1 ratio)

Coupe stabilizer bars:

- 34 x 5.8 mm tubular front stabilizer bar
- 24 mm solid rear bar
- Tokico twin tube shocks and struts

Convertible stabilizer bars:

- 34 x 5.1 mm tubular front stabilizer bar
- 20 mm solid rear bar
- Tokico twin tube shocks and struts

Spring rates:

- 34.1 N/mm front and 29.2 N/mm rear (Coupe)
- 31.0 N/mm front and 23.0 N/mm rear (Convertible)

WHEELS

Your SVT vehicle is equipped with unique wheels matched to the tires. These wheels are more susceptible to damage due to their diameter, width and low profile tires. To avoid damage to your wheels:

- Maintain proper tire pressure (see *Tires* previously listed).
- Do not drive your vehicle through an automated, commercial car wash due to the vehicle's low ground clearance, tire width and track. Wash your vehicle by hand, with a commercial wand, or by using a touchless commercial wash with no mechanical tracks on the floor.
- When installing wheels, always torque lug nuts to specification with a torque wrench.
- Inspect your wheels for damage on a regular basis. If a wheel is damaged, replace it immediately.
- In the event that you encounter an abnormally harsh impact, inspect the outer diameter of your wheels, both inside and out, for damage.

Operating at high speeds

Your SVT vehicle is capable of high speeds and is equipped with tires rated for the vehicle's maximum speed. Remember to drive safely, obey all traffic laws and only operate your SVT vehicle at high speeds at locations equipped and designed to do so safely. Before operating your vehicle at high speeds:

Chassis

- Ensure correct tire pressures (see *Tires* previously listed).
- Inspect wheels and tires for wear and damage. Replace any damaged wheels or tires.
- Do not operate your vehicle at high speeds with more than two passengers or while carrying cargo.

Winter driving

The original equipment tires on your SVT vehicle are designed for maximum performance in dry and wet summer conditions. They are not designed for winter use on ice or snow and cannot be used with snow chains. If you will be operating your vehicle in these conditions, winter or all-season tires must be used.

- Use winter tires on all four wheels and use P255/45R18 tires with a “V” speed rating and a 93 load index or higher.
- Winter tires must be of the proper speed and load ratings.
- Be aware that winter or all-season tires will not perform as well as the original equipment tire in dry and wet conditions. Expect handling, steering and braking to be degraded.
- Do not use a winter tire with less than a “V” speed rating, and even with clear, dry driving conditions do not operate your vehicle above posted speed limits while using winter tires. Never perform high speed driving with winter tires.

Wheel lug nut torque specifications

Retighten the lug nuts to the specified torque at 500 miles (800 km) after any wheel disturbance (tire rotation, changing a flat tire, wheel removal, etc.).

Bolt size	Wheel lug nut torque*	
	lb.ft.	N•m
½ x 20	100	135

* Torque specifications are for nut and bolt threads free of dirt and rust. Use only Ford recommended replacement fasteners.



When a wheel is installed, always remove any corrosion, dirt or foreign materials present on the mounting surfaces of the wheel or the surface of the wheel hub, brake drum or brake disc that contacts the wheel. Ensure that any fasteners that attach the rotor to the hub are secured so they do not interfere with the mounting surfaces of the wheel. Installing wheels without correct metal-to-metal contact at the wheel mounting surfaces can cause the wheel nuts to loosen and the wheel to come off while the vehicle is in motion, resulting in loss of control.

Chassis

IMPORTANT TIRE INFORMATION

Your SVT vehicle is equipped with unique wheels and tires designed to enhance performance. To continue providing this performance, extra care must be taken when operating and maintaining your vehicle.

Wheels and Tires

Tires	Front: P255/45R18 Goodyear Eagle F1 Supercar Rear: P285/40R18 Goodyear Eagle F1 Supercar
Wheels	18 x 9.5 in. Aluminum Multispoke, + 45 mm offset

Tires

Your SVT vehicle is equipped with low profile, high performance tires that are designed to optimize the driving dynamics you expect in a SVT vehicle. These tires are not optimized for off-road or winter (snow or cold weather) performance, and their ride, noise and wear characteristics are different than non-performance tires. Also, because of their lower profile, the tires are more susceptible to damage due to potholes and rough roads. To ensure that your tires perform as intended, it is important that you maintain your tires properly:

- The Shelby GT500 original equipment tires are optimized for performance in both wet and dry conditions. Ford does not recommend using the original equipment tires when temperatures are below 40°F (5°C) or in snow/ice conditions.
- **Do not use tire chains** on the P255/45R18 (front) or P285/40R18 (rear) tires supplied with your vehicle. The use of any type of tire chain on these tires may damage your vehicle.
- For tire pressures, see the placard located on the B-pillar inside the driver's door.
- Always maintain your tire pressures according to the tire information placard on the doorjamb, using an accurate gauge.
- Tire pressures are specified "cold" and should be checked after the vehicle has been parked for at least 3 hours. Do not reduce pressure of warm tires.
- Check your tire pressure often to maintain it properly. Tire pressure can diminish over time and fluctuate with temperature.
- Do not overload your vehicle. Maximum vehicle and axle weights are listed on the tire information placard.
- Extra caution should be taken when operating the vehicle near its maximum load, including assuring proper tire pressure and reducing speeds.

Chassis

- Extra caution should be taken when operating on rough roads to avoid impacts that could cause tire damage.
- In the event that you encounter an abnormally harsh impact, inspect your tires for damage.
- Inspect your tires for damage on a regular basis. If a tire is damaged, replace it immediately.
- Proper suspension alignment is critical for maximum performance and optimal tire wear. If you notice uneven tire wear, have your alignment checked.
- Rotate tires as recommended in the following section *Tire rotation*.
- When replacing tires, the only way to assure original performance is to use the original equipment tire. If a different tire is used, it should be the same size, speed rating and load rating and be replaced as a set of four. Never mix tire brands.

Tire rotation

Because your vehicle is equipped with unique larger tires on the rear wheels, you can only rotate the tires side to side. You must not rotate tires in a crisscross pattern or front to rear. If you notice that the tires wear unevenly, have them checked.

Rotating your tires at the recommended interval (as indicated in the *Scheduled maintenance guide*) will help your tires wear more evenly, providing better tire performance and longer tire life. Unless otherwise specified, rotate the tires approximately every 5,000 miles (8,000 km).

- Tire rotation (front tires at the top of the diagram)

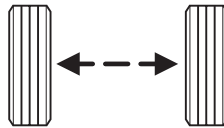
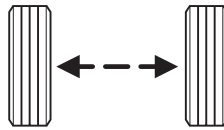

Sometimes irregular tire wear can be corrected by rotating the tires.

Chassis

Note: If your tires show uneven wear, ask an authorized dealer to check for and correct any wheel misalignment, tire imbalance or mechanical problem involved before tire rotation.

Note: After having your tires rotated, inflation pressure must be checked and adjusted to the vehicle requirements.

Roadside Emergencies

TEMPORARY MOBILITY KIT

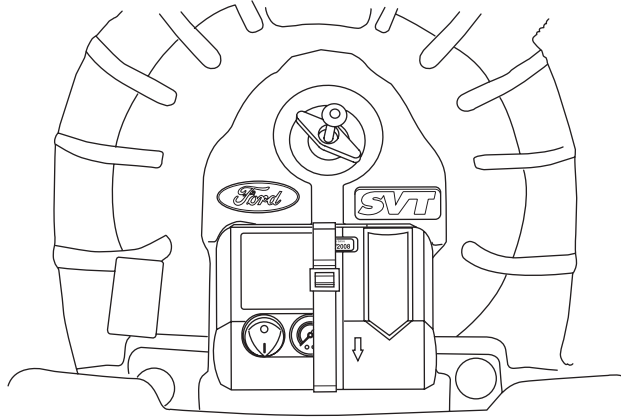

Your vehicle is equipped with an temporary mobility kit (located in the spare tire well in the trunk). The temporary mobility kit consists of an air compressor to reinflate the tire and a sealing compound that will effectively seal most punctures caused by nails or similar objects. This kit will provide a temporary seal allowing you to drive your vehicle up to 120 miles at a maximum speed of 50 mph.

Note: The temporary mobility kit is to be used for one tire only. See your authorized dealer for additional kits.

General information

It is possible that, especially with tire punctures larger than $\frac{1}{4}$ inch or damage to the tire's sidewall, a tire cannot be completely sealed.

Note: Do not use the temporary mobility kit if a tire has become severely damaged by driving the vehicle with a tire that has insufficient air pressure or is totally flat. Only punctured areas located within the tire tread can be sealed with the temporary mobility kit. **For safety reasons, damage to the sidewall must not be repaired.**

Loss of air pressure may adversely affect tire performance. For this reason:

- **Do not** drive the vehicle above 50 mph (80 km/h).
- **Do not** drive further than 120 miles (200 km/h). Drive only to the closest authorized dealer or tire dealer.

Roadside Emergencies

- Drive carefully and avoid abrupt steering maneuvers.
- Periodically monitor tire inflation pressure in the affected tire; if the tire is losing pressure, have the vehicle towed.
- Read the information in the *Tips for use of the temporary mobility kit* section to ensure safe operation of the temporary mobility kit and your vehicle.

Tips for use of the temporary mobility kit

Read the following list of tips to ensure safe operation of the temporary mobility kit:

- Before operating the temporary mobility kit, make sure your vehicle is safely off the road and away from moving traffic.
- Always set the parking brake to ensure the vehicle doesn't move unexpectedly.
- Do not remove any foreign objects, such as nails or screws, from the tire.
- When using the temporary mobility kit, leave the engine running **(only if the vehicle is outdoors or in a well-ventilated area)** so the compressor doesn't drain the vehicle's battery.
- Do not allow the compressor to operate continuously for more than 10 minutes; this will help prevent the compressor from overheating.
- Never leave the temporary mobility kit unattended when it is operating.
- Keep the temporary mobility kit away from children.
- Only use the temporary mobility kit when the ambient temperature is above -20°F (-29°C).
- Only use the temporary mobility kit for sealing/inflating the tires on your vehicle. Do not use the kit for inflating tires on motorcycles, bicycles or any other type of tire.
- Only use the sealing compound before the expiration date. The expiration date is labeled on the unit.
- Do not store the temporary mobility kit inside the passenger compartment of the vehicle as it may cause injury during a sudden stop or collision. Store the kit in its proper location.

Roadside Emergencies

What to do when a tire is punctured

A tire puncture within the tire's tread area can be repaired in two stages with the temporary mobility kit:

- In the first stage, the tire will be reinflated with a sealing compound and air. After the tire has been reinflated, you will need to drive the vehicle a short distance (approximately two miles) to activate the sealing compound inside the tire.
- In the second stage, you will need to check the tire pressure and, if necessary, adjust tire inflation to its proper pressure.

First stage: Reinflating the tire with sealing compound and air

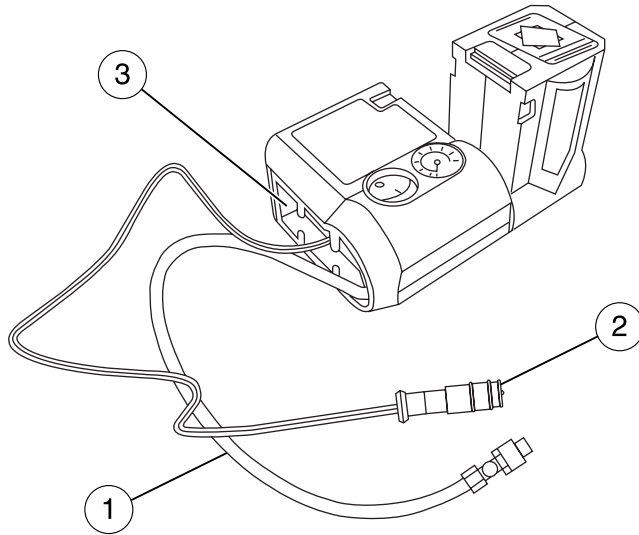

1. Remove the hose (1) and the cable with the electrical plug (2) from the kit's storage compartment (3).
2. Remove the valve cap from the punctured tire, then screw the hose firmly onto the tire's air valve.
3. Insert the electrical plug into the vehicle's dash mounted power point.

Roadside Emergencies

4. Loosen the safety latch (4) on the sealing compound container (5) and rotate the container until it is upright and clicks into place.

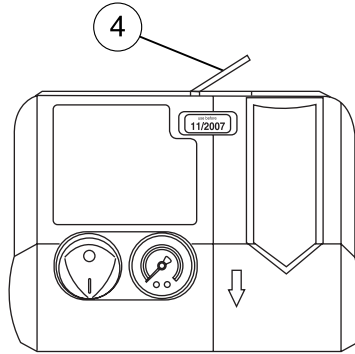

5. Peel the speed limit sticker (6) off the side of the container and affix it to the center of the steering wheel or the instrument panel so it can be seen in plain view.

6. Start the engine (**only if the vehicle is outdoors or in a well-ventilated area**) to prevent the vehicle's battery from draining.

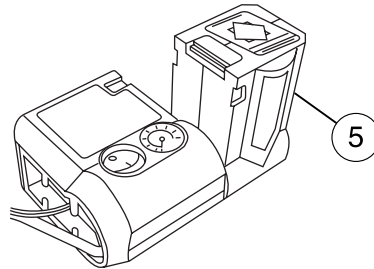

Do not start your vehicle in a closed garage or in other enclosed areas. The carbon monoxide in exhaust fumes can be toxic. Always open the garage door before you start the engine.

7. Turn the air compressor on by pressing the "I" side of the orange button.

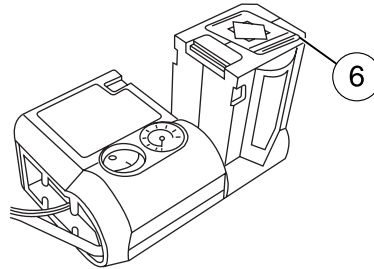

Roadside Emergencies

Note: When the sealing compound is first added into the tire, the air pressure gauge reading (7) on the compressor unit may increase up to 90 psi; this is normal and should be no reason for concern. The pressure will drop after about 30 seconds of operation.

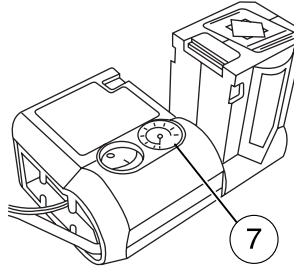

Do not stand directly over the temporary mobility kit while inflating the tire. If you notice any unusual bulges or deformations in the tire's sidewall during inflation, stop the air compressor and deflate the tire using the pressure release valve. The pressure release valve is located on the hose.

8. Inflate the tire until the tire reaches the recommended placard pressure, then turn the air compressor off by pressing the "O" side of the orange button.

Note: If the damaged tire does not reach the recommended placard pressure within nine minutes, the tire is too severely damaged and the car must not be driven. Call for roadside assistance.

9. Once the tire pressure reaches the recommended placard pressure, quickly unscrew the hose from the tire's air valve and reinstall the valve cap. Unplug the electrical plug from the power point. Turn the sealing compound container back to its original position and close the safety latch. Stow the temporary mobility kit back in the original location. You will need it again to check the tire's air pressure in the second stage of this operation.

10. Immediately, and cautiously, drive the vehicle a short distance (approximately two miles) to activate the sealing compound within the damaged tire. Do not exceed 50 mph (80 km/h).

Note: If you experience any unusual vibration, ride disturbance or noise while driving, reduce your speed until you can safely pull off to the side of the road to call for roadside assistance. **Do not proceed to the second stage of this operation.**

Roadside Emergencies

Second stage: Checking tire pressure

1. Stop driving after approximately two miles. Then check the air pressure of the damaged tire as follows:

- Ensure the compressor is turned off by pressing the “O” side of the orange button.
- Remove the hose and the cable with the electrical plug from the kit’s storage compartment.
- Remove the valve cap from the sealed tire, then screw the hose firmly onto the tire’s air valve.
- Start the engine (**only if the vehicle is outdoors or in a well-ventilated area**) to prevent the vehicle’s battery from draining.
- Insert the electrical plug into the vehicle’s power point.
- Read the air pressure gauge on the temporary mobility kit.

2. If the air pressure reads 19 psi (131 kPa) or higher, switch the air compressor on by pressing the “T” side of the orange button and adjust the air pressure to the recommended pressure. This pressure can be found on a label affixed to the B-Pillar or the edge of the driver’s door. If the air pressure is higher than the label states, reduce the excess pressure by pressing down on the pressure release valve (8).

Roadside Emergencies

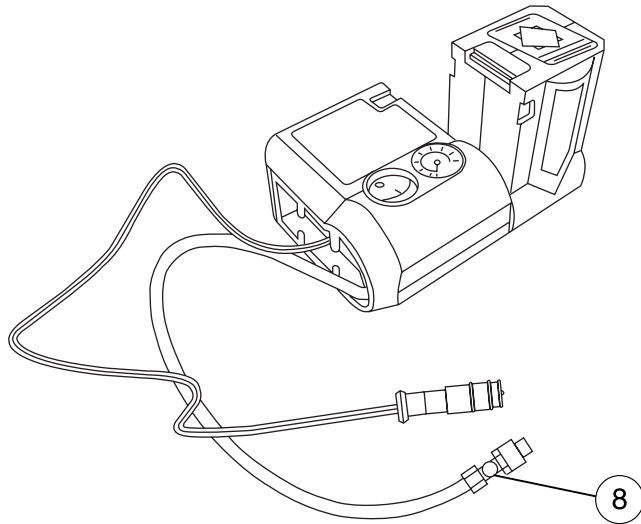

Note: Before driving any further, adjust the tire pressure to the recommended pressure on the vehicle's tire placard located on the B-pillar inside the driver's door.

3. Turn the air compressor off by pressing the "O" side of the orange button, then unscrew the hose from the tire's air valve, reinstall the tire valve cap, unplug the electrical plug from the power point and stow the temporary mobility kit in its original location.

What to do after the tire has been sealed

After using the temporary mobility kit to seal your tire, you will need to replace the sealing compound and hose. Sealing compound and spare parts can be obtained and replaced at an authorized dealer or tire dealer. Empty sealing compound bottles may be disposed of at home; however, liquid residue from the sealing compound should be disposed of by your authorized dealer or tire dealer, or in accordance with local waste disposal regulations.

Note: After the sealing compound has been used, the maximum vehicle speed is 50 mph (120 km/h) and the maximum driving distance is 120 miles (200 km). The sealed tire should be replaced immediately, or at least within the 120 miles (200 km). After sealant use, the TPM (Tire Pressure Monitoring) sensor located inside the wheel, must be replaced by an authorized Ford dealer.

Roadside Emergencies

Note: If you experience any unusual vibration, ride disturbance or noise while driving, reduce your speed until you can safely pull off to the side of the road to call for roadside assistance.

You can check the tire pressure any time within the 120 miles (200 km) by performing the following:

1. Ensure the compressor is turned off by pressing the “O” side of the orange button.
2. Remove the hose and the cable with the electrical plug from the kit’s storage compartment.
3. Remove the valve cap from the sealed tire, then screw the hose firmly onto the tire’s air valve.
4. Insert the electrical plug into the vehicle’s power point.
5. Start the engine (**only if the vehicle is outdoors or in a well-ventilated area**) to prevent the vehicle’s battery from draining.
6. Read the air pressure gauge on the temporary mobility kit.

If the tire pressure needs to be increased, operate the air compressor and inflate the tire to the recommended pressure as indicated on the label on the B-Pillar or the edge of the driver’s door.

AUXILIARY RELAY BOX

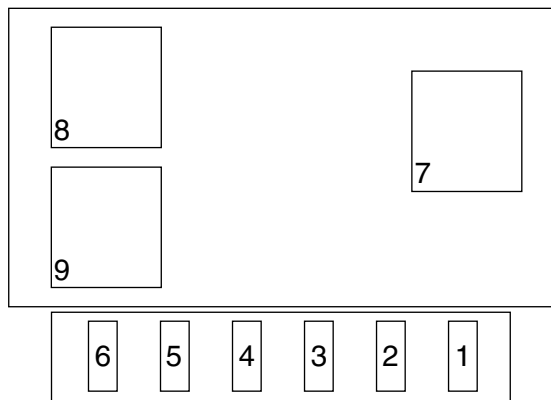

The relay box is located in the engine compartment by the power distribution box.

Roadside Emergencies

Fuse/Relay location	Fuse amp rating	Description
1	—	Not used
2	—	Not used
3	—	Not used
4	—	Not used
5	10A	Intercooler Pump
6	15A	Fuel Pump #2
7	—	Not used
8	—	Fuel pump relay #2
9	—	S.C. Intercooler pump relay

Roadside Emergencies

WRECKER TOWING

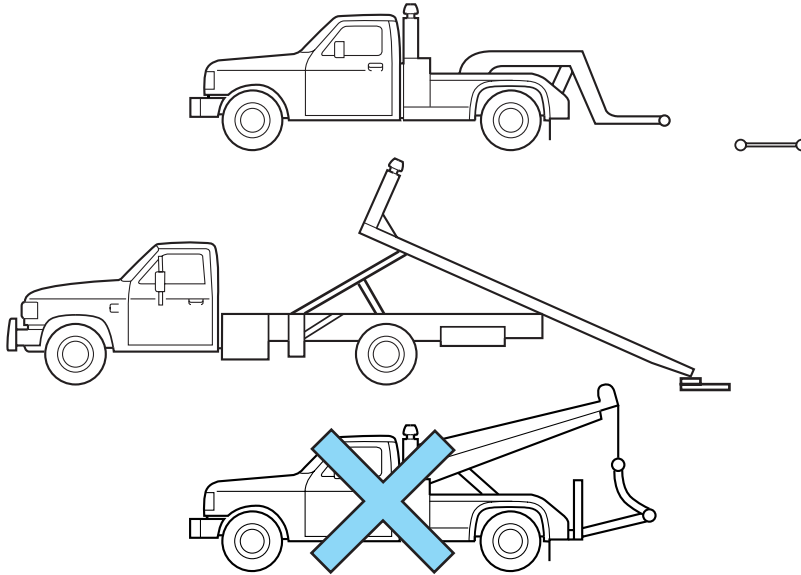

If you need to have your vehicle towed, contact a professional towing service or, if you are a member, your roadside assistance center.

It is recommended that your vehicle be towed with a wheel lift and dollies or with flatbed equipment. When towing with a flatbed, 4x4 blocks must be used when loading/unloading your vehicle. Do not tow with a slingbelt. Ford Motor Company has not approved a slingbelt towing procedure.

If the vehicle is towed by other means or incorrectly, vehicle damage may occur.

Ford Motor Company produces a towing manual for all authorized tow truck operators. Have your tow truck operator refer to this manual for proper hook-up and towing procedures for your vehicle.

Roadside Emergencies

Transportation instructions

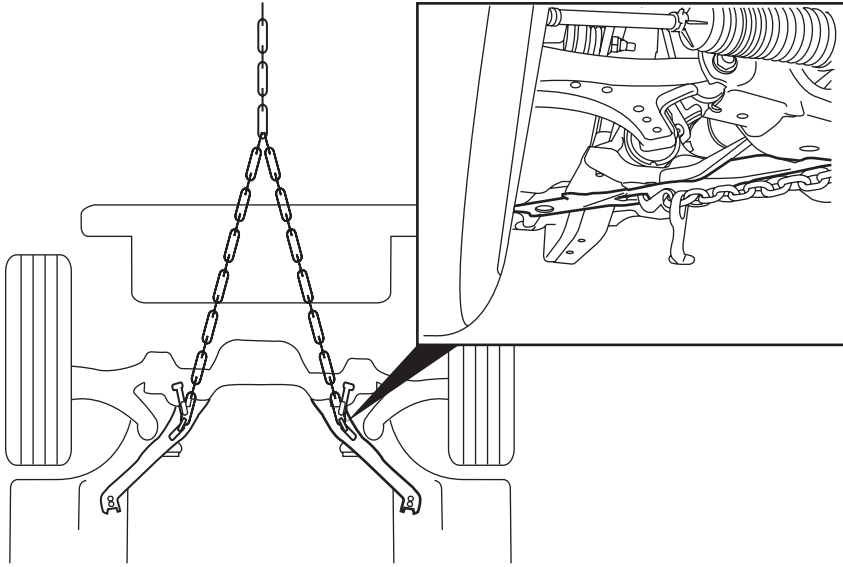

When towing the vehicle, ensure that you use two mini J hooks and adhere them to the crossmember oblong holes as shown. Other methods may damage the vehicle.

Roadside Emergencies

Wheel lift

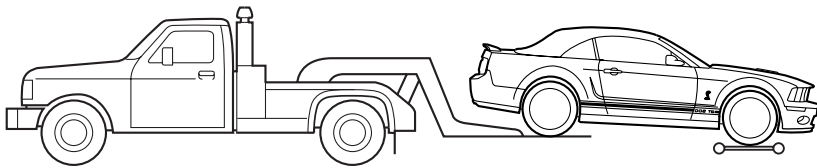
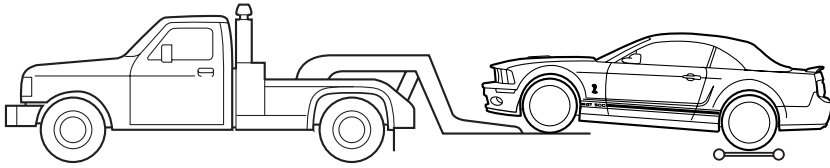

When towing the Shelby GT500, for front loading, the front tires must be 16 in. (41 cm) higher than the rear.

For rear loading, the rear tires must be 14 in. (36 cm) higher than the front.

Roadside Emergencies

Flatbed

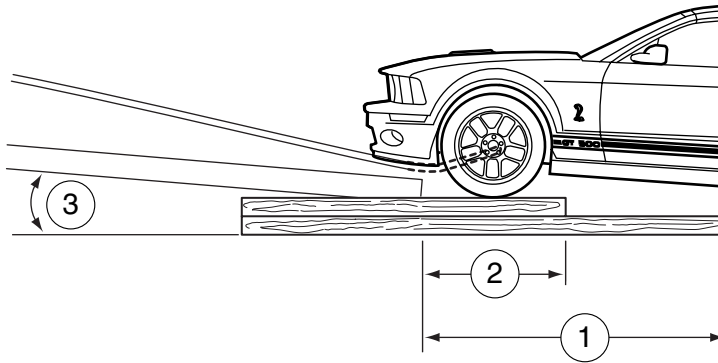

1. 36 in. (91 cm) 4x4 loading block
2. 18 in. (45.72 cm) 4x4 loading block
3. 11.5° maximum

Maintenance and Specifications

5.4L DOHC SUPERCHARGED V-8 ENGINE

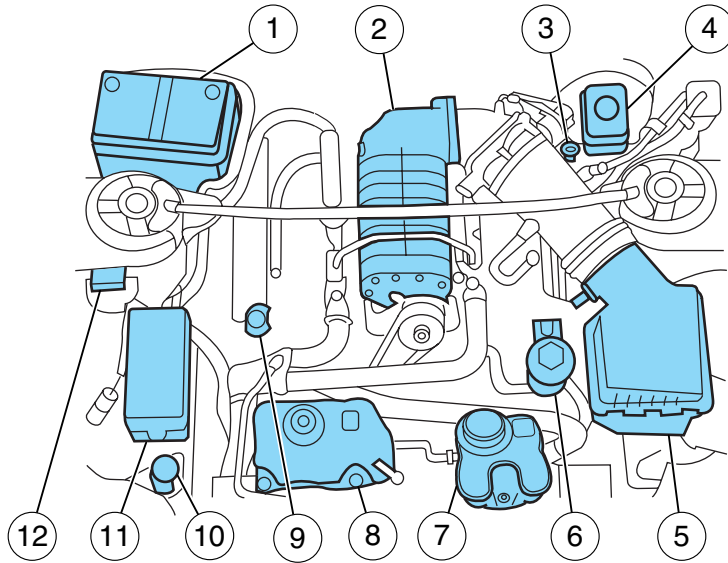

1. Battery
2. Supercharger
3. Engine oil dipstick
4. Brake fluid reservoir
5. Air Filter Assembly
6. Power Steering Fluid Reservoir
7. Intercooler coolant reservoir
8. Engine coolant reservoir
9. Engine oil filler cap
10. Windshield washer reservoir
11. Power distribution box
12. Auxiliary Fuse Box

Maintenance and Specifications

ENGINE OIL RECOMMENDATION

Use Motorcraft SAE 5W-50 full synthetic or an equivalent SAE 5W-50 full synthetic oil meeting Ford specification WSS-M2C931-B.

Do not use supplemental engine oil additives, cleaners or other engine treatments. They are unnecessary and could lead to engine damage that is not covered by Ford warranty.

Change your engine oil and filter according to the appropriate schedule listed in the Scheduled Maintenance Guide.

ENGINE AND INTERCOOLER COOLANT

The concentration and level of engine coolant should be checked at the mileage intervals listed in the scheduled maintenance guide. The coolant concentration should be maintained at 50/50 coolant and water, which equates to a freeze point of -36°C (-34°F). Coolant concentration testing is possible with a hydrometer or antifreeze tester (such as the Rotunda Battery and Antifreeze Tester, 0014-R1060). The level of coolant should be maintained at the “cold full” or “cold fill range” level in the coolant reservoir. If the level falls below, add coolant per the instructions in the *Adding Engine Coolant* section.

Your vehicle was factory-filled with a 50/50 engine coolant and water concentration. If the concentration of coolant falls below 40% or above 60%, the engine parts could become damaged or not work properly. **A 50/50 mixture of coolant and water provides the following:**

- **freeze protection down to -36°C (-34°F).**
- **boiling protection up to 129°C (265°F).**
- **protection against rust and other forms of corrosion.**
- **an accurate temperature readout from the engine coolant gauge.**

Maintenance and Specifications

When the engine is cold, check the level of the engine coolant in the reservoir.

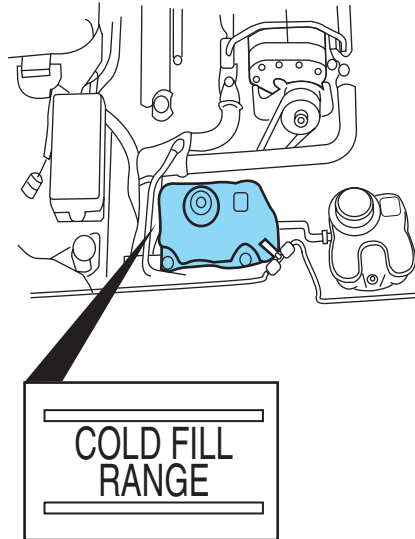

- The engine coolant should be at the “cold fill level” as listed on the engine coolant reservoir.
- Refer to the scheduled maintenance guide for service interval schedules.
- Be sure to read and understand *Precautions when servicing your vehicle* in this your *Owner's Guide*.

If the engine coolant has not been checked at the recommended interval, the engine coolant reservoir may become low or empty. If the reservoir is low or empty, add engine coolant to the reservoir. Refer to *Adding engine coolant* in this chapter.

Note: Automotive fluids are not interchangeable; do not use engine coolant, antifreeze or windshield washer fluid outside of its specified function and vehicle location.

Adding engine coolant

When adding coolant, make sure it is a 50/50 mixture of engine coolant and distilled water. Add the mixture to the coolant reservoir, **when the engine is cool**, until the appropriate fill level is obtained.

Maintenance and Specifications



Do not add engine coolant when the engine is hot. Steam and scalding liquids released from a hot cooling system can burn you badly. Also, you can be burned if you spill coolant on hot engine parts.



Do not put engine coolant in the windshield washer fluid container. If sprayed on the windshield, engine coolant could make it difficult to see through the windshield.

The cooling system in your vehicle is filled with either green-colored Motorcraft Premium Engine Coolant meeting Ford specification ESE-M97B44-A or yellow-colored Motorcraft Premium Gold Engine Coolant meeting Ford Specification WSS-M97B51-A1. To determine your vehicle's coolant type (color), check your coolant reservoir.

- **Add Motorcraft Premium Engine Coolant (green-colored), VC-4-A (U.S.) or CXC-10 (Canada) or Motorcraft Premium Gold Engine Coolant (yellow-colored), VC-7-A, depending on the type of coolant originally equipped in your vehicle.** If you are unsure which type of coolant your vehicle requires, check your coolant reservoir or contact your local dealer.
- **Do not add/mix an orange-colored, extended life coolant such as Motorcraft Speciality Orange Engine Coolant, VC-2 (US) or CXC-209 (Canada), meeting Ford specification WSS-M97B44-D with the factory-filled coolant.** Mixing Motorcraft Speciality Orange Engine Coolant or any orange-colored extended life product with your factory filled coolant can result in degraded corrosion protection.
- A large amount of water without engine coolant may be added, in case of emergency, to reach a vehicle service location. In this instance, the cooling system must be drained and refilled with a 50/50 mixture of engine coolant and distilled water as soon as possible. Water alone (without engine coolant) can cause engine damage from corrosion, overheating or freezing.
- **Do not use alcohol, methanol or brine or any engine coolants mixed with alcohol or methanol antifreeze (coolant).** Alcohol and other liquids can cause engine damage from overheating or freezing.
- **Do not add extra inhibitors or additives to the coolant.** These can be harmful and compromise the corrosion protection of the engine coolant.
- **Do not mix with recycled coolant unless from a Ford-approved recycling process (see *Use of Recycled Engine Coolant* section).**

Maintenance and Specifications



To reduce the risk of personal injury, make sure the engine is cool before unscrewing the coolant pressure relief cap. The cooling system is under pressure; steam and hot liquid can come out forcefully when the cap is loosened slightly.

If you must remove the pressure relief cap or radiator cap (depending upon engine application), follow these steps to avoid personal injury:

1. Before you remove the cap, turn the engine off and let it cool.
2. When the engine is cool, wrap a thick cloth around the cap. Slowly turn cap counterclockwise until pressure begins to release.
3. Step back while the pressure releases.
4. When you are sure that all the pressure has been released, use the cloth to turn it counterclockwise and remove the cap.

Engine coolant refill procedure

The following procedure should be used when refilling the cooling system after it has been drained or become extremely low.

1. Remove the pressure relief cap from the engine coolant reservoir as previously outlined.
2. Slowly add a **50/50 mixture** of engine coolant and distilled water to the engine coolant reservoir until the coolant level is at the “cold fill level” as listed on the reservoir.
3. Reinstall the pressure relief cap.
4. Start and idle the engine until the upper radiator hose is warm (this indicates the thermostat is open and coolant is flowing through the entire system).
5. Shut the engine off and let it cool.
6. Remove the pressure relief cap from the engine coolant reservoir as previously outlined.
7. Add a **50/50 mixture** of engine coolant and distilled water to the engine coolant reservoir until the coolant level is at the “cold fill level” as listed on the reservoir.
8. Reinstall the pressure relief cap.
9. Check the coolant level in the reservoir before you drive your vehicle the next few times (with the engine cool).
10. If necessary, add a **50/50 mixture** of engine coolant and distilled water to the engine coolant reservoir until the coolant level is at the “cold fill level” as listed on the reservoir.

Maintenance and Specifications

After any coolant has been added, check the coolant concentration (refer to *Checking Engine Coolant*). If the concentration is not 50/50 (protection to $-34^{\circ}\text{F}/-36^{\circ}\text{C}$), drain some coolant and adjust the concentration. It may take several drains and additions to obtain a 50/50 coolant concentration.

Whenever coolant has been added, the coolant level in the coolant reservoir should be checked the next few times you drive the vehicle. If necessary, add enough 50/50 concentration of engine coolant and distilled water to bring the liquid level to the proper level.

If you have to add more than 1.0 liter (1.0 quart) of engine coolant per month, have your dealer check the engine cooling system. Your cooling system may have a leak. Operating an engine with a low level of coolant can result in engine overheating and possible engine damage.

OCTANE RECOMMENDATIONS

Your vehicle is designed to use “Premium” unleaded gasoline with an (R+M)/2 octane rating of 91 or higher for optimum performance.

The use of gasolines with lower octane ratings may degrade performance. We do not recommend the use of gasolines labeled as “Premium” in high altitude areas that are sold with octane ratings of less than 91.

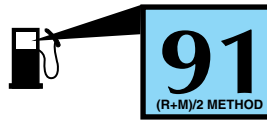

If your engine knocks under most driving conditions while you are using fuel with the recommended octane rating, see your authorized dealer to prevent any engine damage.

AIR FILTER

Refer to *scheduled maintenance information* for the appropriate intervals for changing the air filter element.

When changing the air filter element, use only the Motorcraft air filter element listed. Refer to *Motorcraft part numbers* in this chapter.



To reduce the risk of vehicle damage and/or personal burn injuries do not start your engine with the air cleaner removed and do not remove it while the engine is running.

Maintenance and Specifications

Changing the air filter element

1. Release the clamps that secure the air filter housing cover.
2. Carefully separate the two halves of the air filter housing.
3. Remove the air filter element from the air filter housing.
4. Wipe the air filter housing and cover clean to remove any dirt or debris and to ensure good sealing.
5. Install a new air filter element. Be careful not to crimp the filter element edges between the air filter housing and cover. This could cause filter damage and allow unfiltered air to enter the engine if not properly seated.
6. Replace the air filter housing cover and secure the clamps.

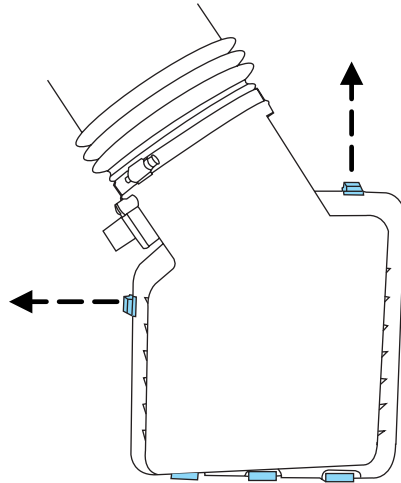

MOTORCRAFT PART NUMBERS

Component	5.4L DOHC Supercharged V-8 engine
Air filter element	FA-1807
Fuel filter	FG-1083
Battery	BXT-40-R
Oil filter	FL-820S
PCV valve	EV-270
Spark plugs*	AGSF-22FM1

* Refer to Vehicle Emissions Control Information (VECI) decal for spark plug gap information.

Maintenance and Specifications

REFILL CAPACITIES

Fluid	Ford Part Name	Capacity
Brake fluid	Motorcraft High Performance DOT 3 Motor Vehicle Brake Fluid	Fill to line on reservoir
Engine oil (includes filter change)	Motorcraft 5W-50 Full Synthetic Motor Oil	6.1L (6.5 quarts)
Engine coolant ¹	Motorcraft Premium Engine Coolant (green-colored) or Motorcraft Premium Gold Engine Coolant (yellow-colored)	20.0L (21.1 quarts)
Power steering fluid	Motorcraft MERCON® ATF	Fill to between MIN and MAX lines on reservoir
Rear axle lubricant ²	Motorcraft SAE 75W-140 High Performance Synthetic Rear Axle Lubricant	2.0L (4.25 pints)
Fuel tank	N/A	59.4L (15.7 gallons)
Intercooler coolant ¹	Motorcraft Premium Engine Coolant (green-colored) or Motorcraft Premium Gold Engine Coolant (yellow-colored)	3.75L (3.96 quarts) (See your authorized dealer for service.)
Transmission fluid ³	MERCON® ATF	3.5L (6.35 pints) ⁴
Windshield washer fluid	Ultra-Clear Windshield Washer Concentrate	3.8L (4.0 quarts)

¹Add the coolant type originally equipped in your vehicle.

Maintenance and Specifications

²Rear axle lubricants do not need to be checked or changed unless a leak is suspected, service is required or the axle assembly has been submerged in water. The axle lubricant should be changed any time the rear axle has been submerged in water, using SAE 75W-140 High Performance rear axle lube, meeting Ford specification WSP-M2C102-A.

Fill 6–14mm (1/4–9/16 in) below bottom of fill hold. Add 118 ml (4 oz) of Addictive Friction Modifier C3AZ-19B546-A or equivalent meeting Ford specification EST-M2C118-A for complete refill of Traction-Lok axles.

³The Tremec TR-6060 6-Speed manual transmission on your Shelby GT500 uses MERCON® automatic transmission fluid. Ensure that the correct MERCON® ATF automatic transmission fluid is used as indicated on the label on your transmission.

⁴Service refill capacity is determined by filling the transmission to the bottom of the filler hole with the vehicle on a level surface.

USING THE RIGHT BULBS

Function	Trade Number
Park lamp, turn lamp, side marker (front)	3156K
Luggage compartment lamp	S211
High-mount brake lamp (Service as complete assembly)	See your Dealer
Fog lamp	PS24N

Maintenance and Specifications

DRIVETRAIN

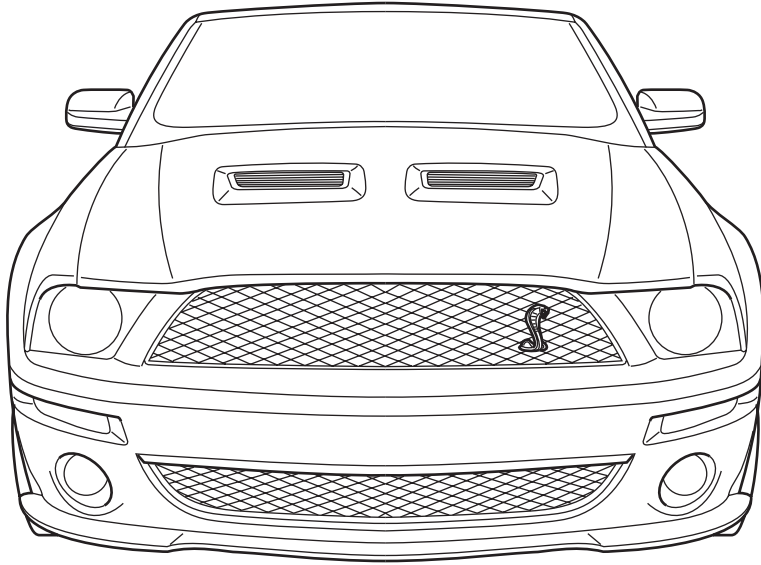

Item	Description	
Rear axle	8.8 in. solid rear axle with limited-slip differential 3.31:1 ratio	
Driveshaft	2 piece steel	
Transmission	Tremec TR-6060 6-speed manual with integral clutch housing	
Gear ratios	<i>Gear</i>	<i>Ratio</i>
	1st	2.97
	2nd	1.78
	3rd	1.30
	4th	1.00
	5th	0.80
	6th	0.63
	Reverse	2.90

Maintenance and Specifications

ENGINE INFORMATION

Item	Description
Configuration	Longitudinally mounted, 90-degree V8, cast-iron cylinder block and cast aluminum cylinder heads
Bore x Stroke	90.2 x 105.8 mm (3.55 x 4.165 in)
Displacement	5410 cc/330 cid
Compression ratio	8.4:1
Horsepower	485 Horsepower @ 6000 rpm
Torque	475 lb-ft torque @ 3750 rpm
Redline	6000 rpm redline 6250 rpm fuel shut-off
Specific output	89.8 HP per liter
Valvetrain	Dual overhead chain-driven cams, roller finger followers with hydraulic lash adjustment, ovate-wire valve springs, four valves per cylinder
Fuel system	Sequential electronic fuel injection
Mass air sensor	130.5 x 80.5 mm (3.54 in) oval
Throttle body	Twin 60 mm (2.36 in) diameter bore-simultaneously open
Pistons	Forged aluminum
Crankshaft	Forged steel
Connecting rods	Forged steel I-beam
Supercharger	Eaton model 122, Roots-type
Exhaust manifolds	Cast high-silicon, molybdenum iron
Exhaust system	Dual stainless steel

Maintenance and Specifications

Engine drivebelt routing

5.4L DOHC 32V Supercharged V-8

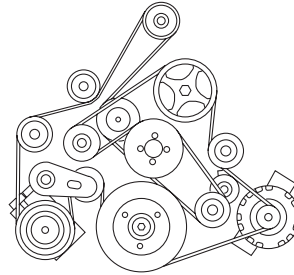

A word about warranty coverage

WARRANTY COVERAGE

The Shelby GT500 carries the same New Vehicle Limited Warranty as other Ford Mustang models. This information is covered in its entirety in the Ford Motor Company Warranty Guide.

Warranty service for the Shelby GT500 or any SVT vehicle can be obtained at any Ford or Lincoln Mercury dealer nationwide.

SVT does not recommend modifying or racing SVT vehicles, as they are designed and built to be driven as delivered from the factory. The Ford Motor Company Warranty Guide discusses vehicle usage and the installation of aftermarket parts and their effect on warranty coverage as follows:

Repairs are not reimbursable under warranty when damage is caused by:

- misusing the vehicle, such as driving over curbs, overloading, racing, or using the vehicle as a stationary power source.
- altering or modifying the vehicle — including the body, chassis, or components — after the vehicle leaves Ford's control.
- non-Ford parts installed after the vehicle leaves Ford's control, including, but not limited to, cellular phones, alarm systems and automatic starting systems.

Please see the Warranty Guide for complete information.